

**DESCRIPTION**

The TL431/TL431A/TL431B series precision adjustable three terminal shunt voltage regulators are pin-to-pin compatible with the industry standard TL431. The output voltage of this reference is programmable by using two external resistors from 2.5V to 36V. These devices offer low output impedance for improved load regulation. The typical output impedance of these devices is 200mΩ. These devices find application in the feedback path of switching power supplies, OVP crowbar circuits, reference for A/D, D/A, and as zener diodes with improved turn-on characteristics.

**IMPORTANT:** For the most current data, consult MICROSEMI's website: <http://www.microsemi.com>

**KEY FEATURES**

- INITIAL VOLTAGE REFERENCE ACCURACY OF 0.4% (TL431B)
- SINK CURRENT CAPABILITY 1mA to 100mA
- TYPICAL OUTPUT DYNAMIC IMPEDANCE LESS THAN 200mΩ; TYPICAL OUTPUT IMPEDANCE OF THE TL431B LESS THAN 100mΩ
- ADJUSTABLE OUTPUT VOLTAGE FROM 2.5V TO 36V
- AVAILABLE IN SURFACE-MOUNT PACKAGES
- LOW OUTPUT NOISE
- TYPICAL EQUIVALENT FULL RANGE TEMPERATURE COEFFICIENT OF 30ppm/°C
- DIRECT PIN-TO-PIN REPLACEMENT FOR INDUSTRY STANDARD TL431 AND TL1431

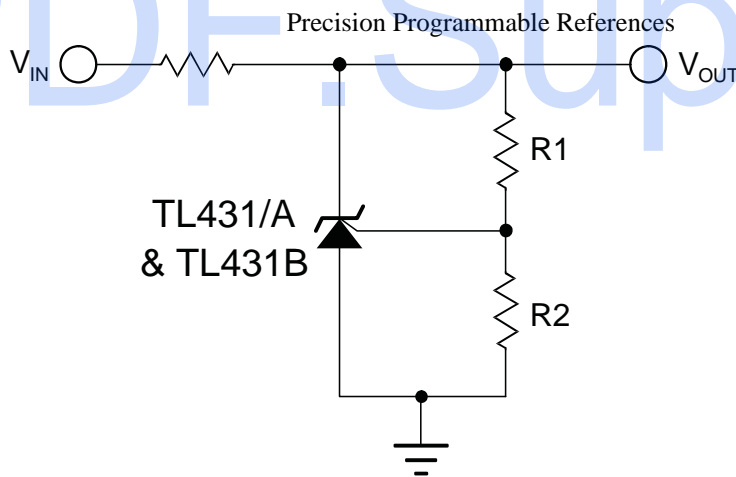
**PRODUCT HIGHLIGHT**

$$V_O = \left(1 + \frac{R1}{R2}\right) \cdot V_{REF}$$

**PACKAGE ORDER INFO**

T <sub>A</sub> (°C)	Initial Tolerance	<b>DM</b> Plastic SOIC 8-Pin	<b>LP</b> Plastic TO-92 3-Pin	<b>PK</b> Plastic TO-89 3 - Pin
		RoHS Compliant / Pb-free Transition DC: 0440	RoHS Compliant / Pb-free Transition DC: 0509	RoHS Compliant / Pb-free Transition DC: 0518
0 to 70	2%	<b>TL431CDM</b>	<b>TL431CLP</b>	<b>TL431CPK</b>
	1%	<b>TL431ACDM</b>	<b>TL431ACL</b>	<b>TL431ACPK</b>
	0.4%	<b>TL431BCDM</b>	<b>TL431BCLP</b>	<b>TL431BCPK</b>
-40 to 85	2%	<b>TL431IDM</b>	<b>TL431ILP</b>	<b>TL431IPK</b>
	1%	<b>TL431AIDM</b>	<b>TL431AILP</b>	<b>TL431AIPK</b>
	0.4%	<b>TL431BIDM</b>	<b>TL431BILP</b>	<b>TL461BIPK</b>

Note: All surface mount packages are available in Tape & Reel. Append the letters "TR" to the part number. (i.e. LTL431AIDM-TR). The TO-92 (LP) package is available in ammo-pack.

**ABSOLUTE MAXIMUM RATINGS**

Cathode to Anode Voltage (VKA)(Note 2) .....	-0.3 to 37V
Reference Input Current (IREF).....	-50µA to 10mA
Continuous Cathode Current (IK).....	-100mA to 150mA
Operating Junction Temperature.....	150°C
Storage Temperature Range.....	-65°C to 150°C
Package Peak Temp. for Solder Reflow (40 seconds maximum exposure) ...	260°C (+0 -5)

Note: Exceeding these ratings could cause damage to the device. All voltages are with respect to Ground. Currents are positive into, negative out of specified terminal.

Note 2. Voltage values are with respect to the anode terminal unless otherwise noted.

**THERMAL DATA**
**DM Plastic SOIC 8-Pin**

THERMAL RESISTANCE-JUNCTION TO AMBIENT, $\theta_{JA}$	165°C/W
---	---------

**PK Plastic TO-89 3-Pin**

THERMAL RESISTANCE-JUNCTION TO AMBIENT, $\theta_{JA}$	71°C/W
---	--------

**LP Plastic TO-92 3-Pin**

THERMAL RESISTANCE-JUNCTION TO AMBIENT, $\theta_{JA}$	156°C/W
---	---------

Junction Temperature Calculation:  $T_J = T_A + (P_D \times \theta_{JA})$ .

The  $\theta_{JA}$  numbers are guidelines for the thermal performance of the device/pc-board system. All of the above assume no ambient airflow.

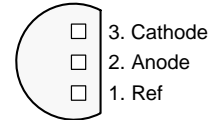
**PACKAGE PIN OUT**

**LP PACKAGE**  
(Top View)

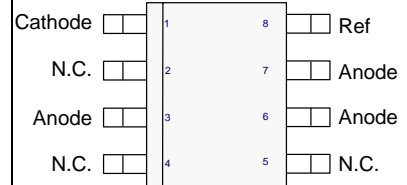

**DM PACKAGE**  
(Top View)

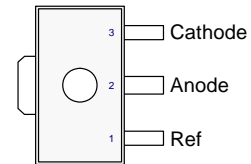

**PK PACKAGE**  
(Top View)

RoHS / Pb-free 100% Matte Tin Lead Finish

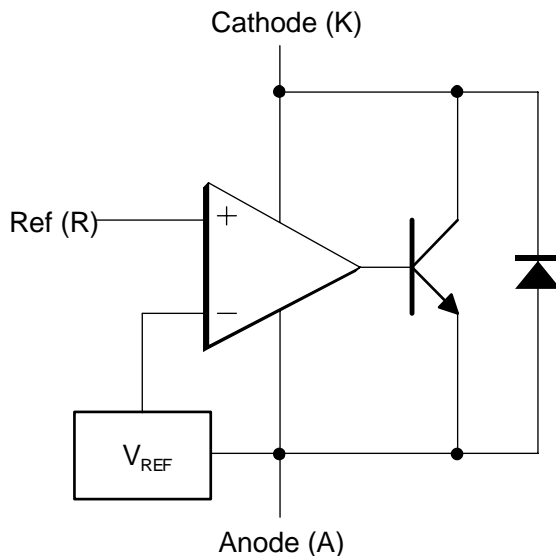
**BLOCK DIAGRAM**

**ELECTRICAL CHARACTERISTICS**

Unless otherwise specified, these specifications apply over the operating ambient temperature for the TL431C/TL431AC/TL431BC with  $0^{\circ}\text{C} \leq T_A \leq 70^{\circ}\text{C}$ , and TL431I/TL431AI/TL431BI with  $-40^{\circ}\text{C} \leq T_A \leq 85^{\circ}\text{C}$

Parameter	Symbol	Test Conditions	TL431/A/B			Units
			Min	Typ	Max	
Reference Input Voltage	TL431	$I_K = 10\text{mA}, V_{KA} = V_{REF}, T_A = 25^{\circ}\text{C}$	2440	2495	2550	mV
	TL431A	$I_K = 10\text{mA}, V_{KA} = V_{REF}, T_A = 25^{\circ}\text{C}$	2470	2495	2520	
	TL431B	$I_K = 10\text{mA}, V_{KA} = V_{REF}, T_A = 25^{\circ}\text{C}$	2490	2500	2510	
Reference Drift	TL431C	$I_K = 10\text{mA}, V_{KA} = V_{REF}$		4	17	mV
	TL431I	$I_K = 10\text{mA}, V_{KA} = V_{REF}$		5	30	
	TL431AC	$I_K = 10\text{mA}, V_{KA} = V_{REF}$		4	17	
	TL431AI	$I_K = 10\text{mA}, V_{KA} = V_{REF}$		5	30	
	TL431BC	$I_K = 10\text{mA}, V_{KA} = V_{REF}$		4	15	
	TL431BI	$I_K = 10\text{mA}, V_{KA} = V_{REF}$		5	20	
Voltage Ratio, Ref to Cathode (Note 4)	TL431, TL431A	$I_K = 10\text{mA}, V_{KA} = 2.5\text{V to } 36\text{V}$		-1.4	-2.7	mV/V
	TL431B	$I_K = 10\text{mA}, V_{KA} = 2.5\text{V to } 36\text{V}$		-1.1	-2.0	
Reference Input Current	TL431, TL431A	$V_{KA} = V_{REF}, T_A = 25^{\circ}\text{C}$		2	4	$\mu\text{A}$
	TL431B	$V_{KA} = V_{REF}, T_A = 25^{\circ}\text{C}$		1.5	1.9	
Minimum Operating Current		$V_{KA} = V_{REF} \text{ to } 36\text{V}$		0.4	1	mA
Off-State Cathode Current	TL431	$V_{KA} = V_{REF} \text{ to } 36\text{V}, T_A = 25^{\circ}\text{C}$		0.1	1	$\mu\text{A}$
	TL431A	$V_{KA} = V_{REF} \text{ to } 36\text{V}, T_A = 25^{\circ}\text{C}$		0.1	1	
	TL431B	$V_{KA} = V_{REF} \text{ to } 36\text{V}, T_A = \text{Operating Range}$			2	
		$V_{KA} = 36\text{V}, V_{REF} = 0\text{V}, T_A = 25^{\circ}\text{C}$		0.18	0.5	
Dynamic Impedance	TL431	$V_{KA} = V_{REF}, I_K = 1\text{mA to } 100\text{mA}, f < 1\text{kHz}, T_A = 25^{\circ}\text{C}$		0.2	0.5	$\Omega$
	TL431B	$V_{KA} = V_{REF}, I_K = 1\text{mA to } 100\text{mA}, f < 1\text{kHz}, T_A = 25^{\circ}\text{C}$		0.1	0.2	

Note 3: These parameters are guaranteed by design.

Note 4:  $\frac{\Delta V_{REF}}{\Delta V_{KA}}$  Ratio of change in reference input voltage to the change in cathode voltage.

**GRAPH / CURVE INDEX****Characteristic Curves**

- Figure #
1. Reference Input Voltage vs. Free-Air Temperature
  2. Reference Input Current vs. Free-Air Temperature
  3. Cathode Current vs. Cathode Voltage
  4. Cathode Current vs. Cathode Voltage
  5. Off-State Cathode Current vs. Free-Air Temperature
  6. Ratio of Delta Reference Voltage to Delta Cathode Voltage vs. Free-Air Temperature
  7. Equivalent Input Noise Voltage vs. Frequency

**FIGURE INDEX****Parameter Measurement Information**

- Figure #
8. Test Circuit For  $V_{KA} = V_{REF}$
  9. Test Circuit For  $V_{KA} > V_{REF}$
  10. Test Circuit for  $I_{OFF}$

**Typical Characteristics**

- Figure #
11. Equivalent Input Noise Voltage Over a 10-Second Period
  12. Small-Signal Voltage Amplification vs. Frequency
  13. Reference Impedance vs. Frequency
  14. Pulse Response
  15. Stability Boundary Conditions

**Application Information**

- Figure #
16. Shunt Regulator
  17. Single-Supply Comparator with Temperature-Compensated Threshold
  18. High Current Shunt Regulator
  19. Crowbar Circuit
  20. Voltage Monitor
  21. Precision Constant-Current Sink

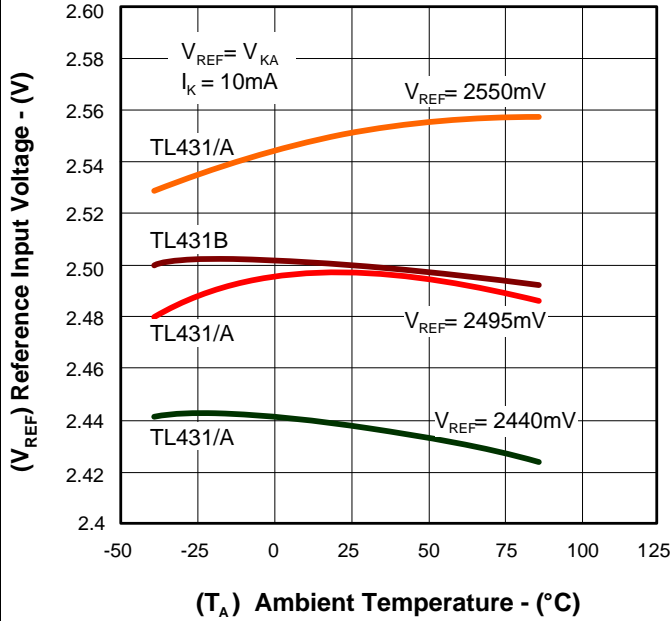
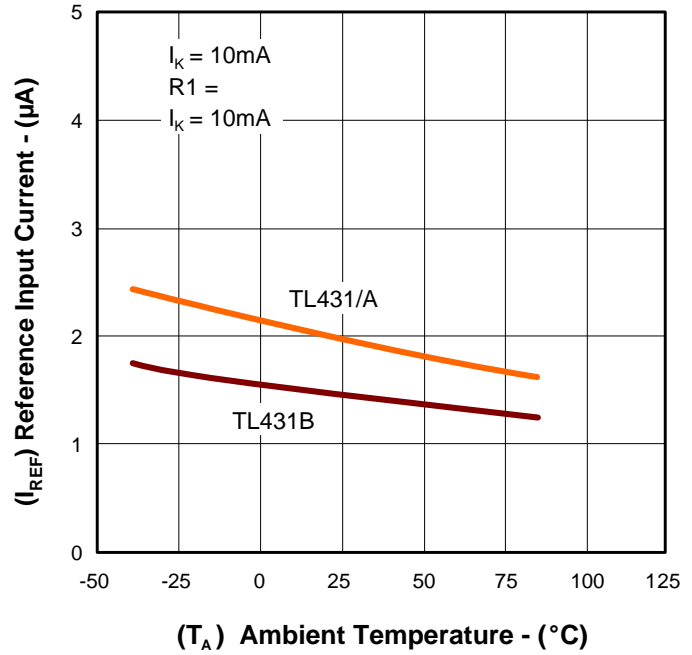
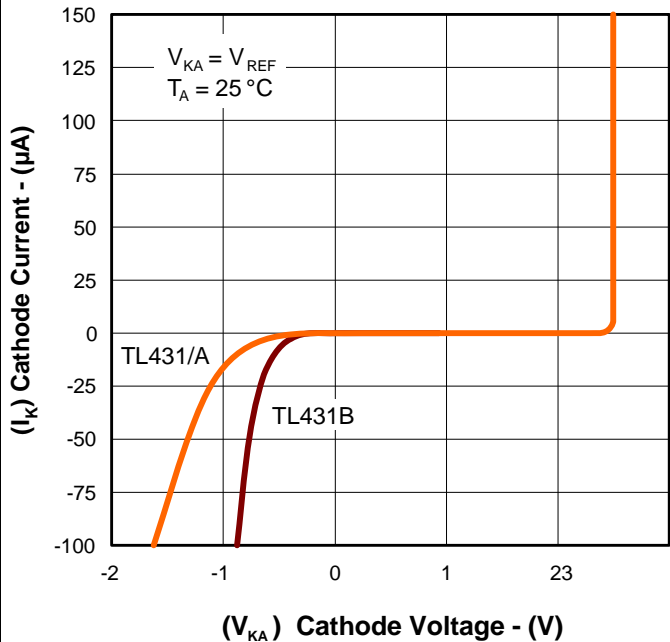
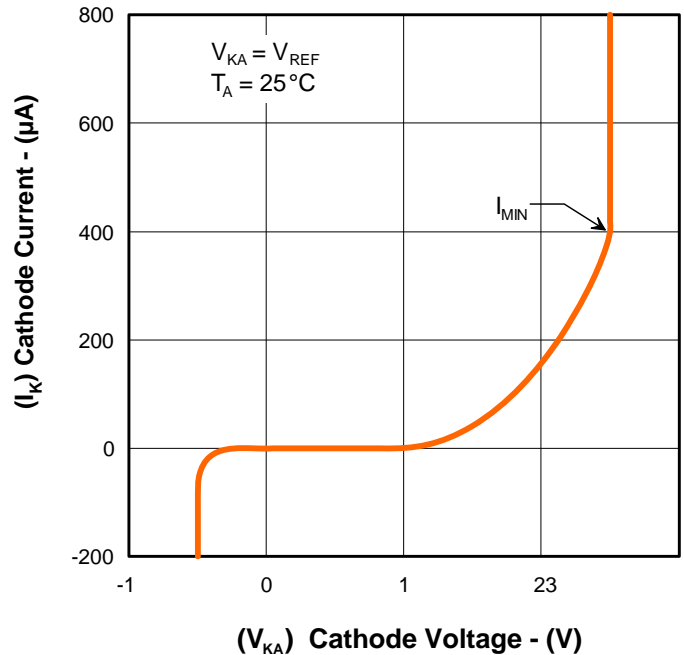
**CHARACTERISTIC CURVES**

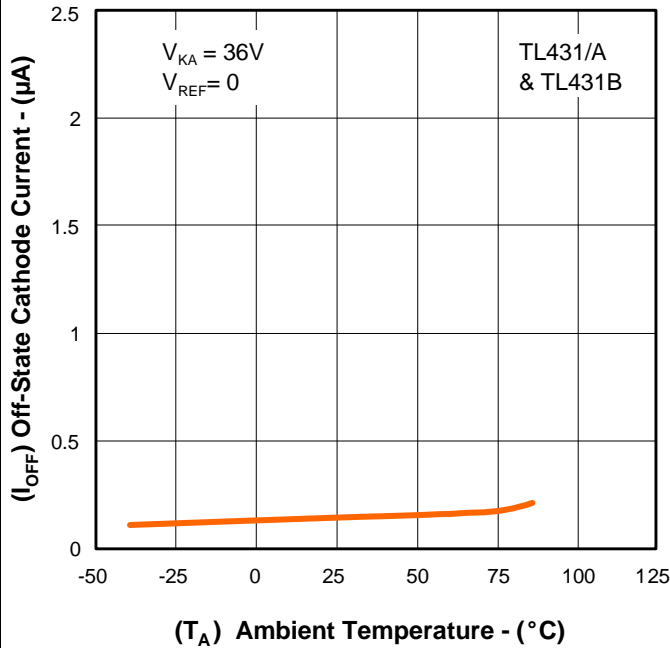
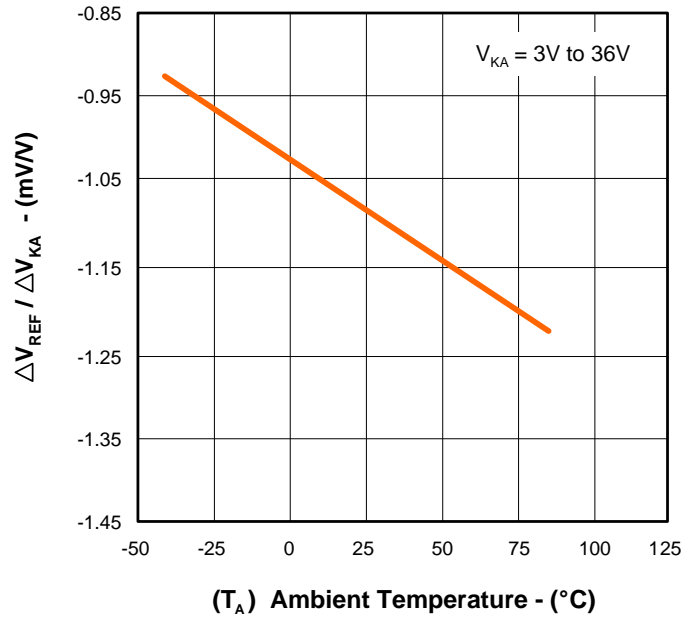
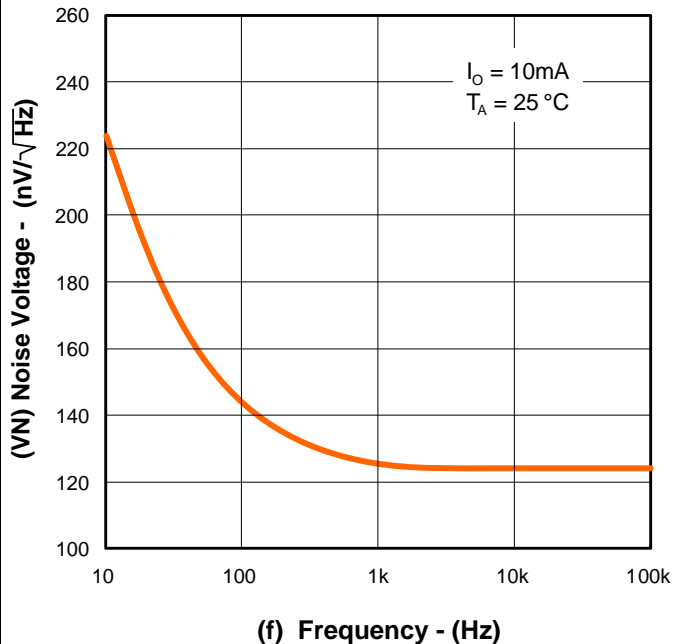
**Figure 1 – Reference Voltage vs. Free-Air Temperature**

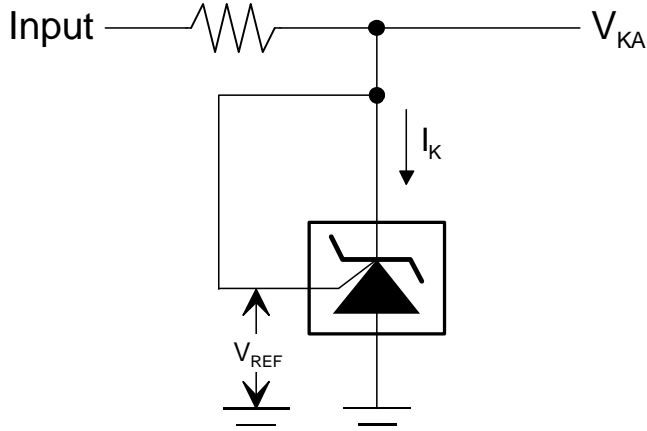
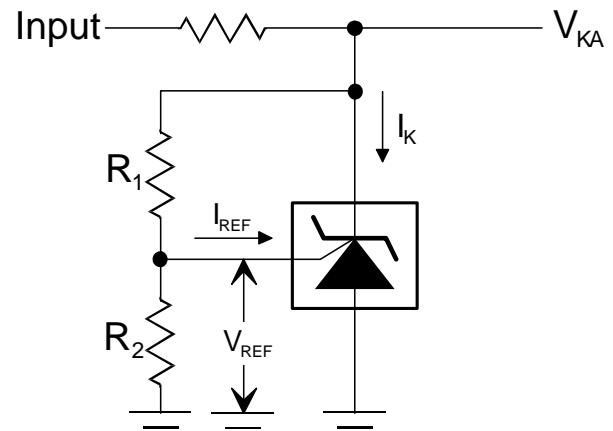
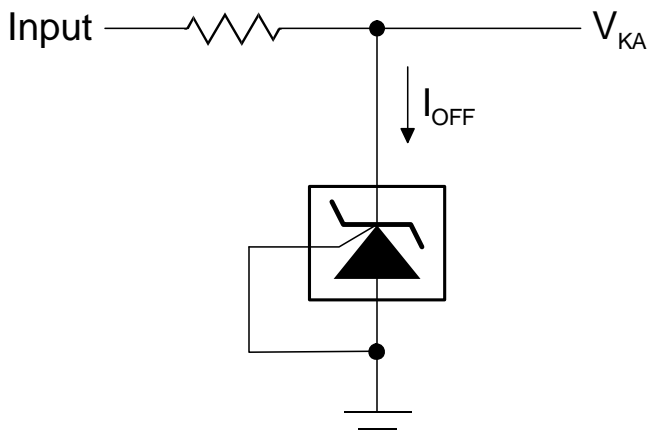
**Figure 2 – Reference Current vs. Free-Air Temperature**

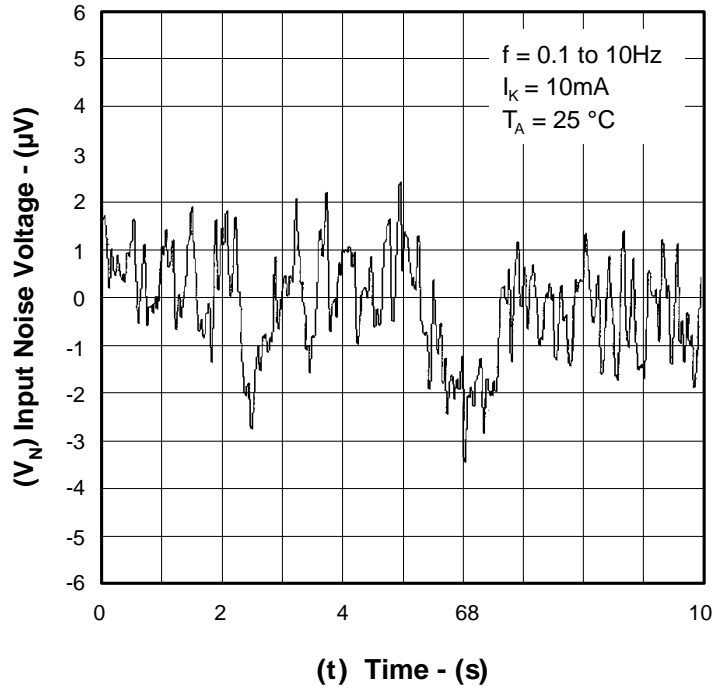
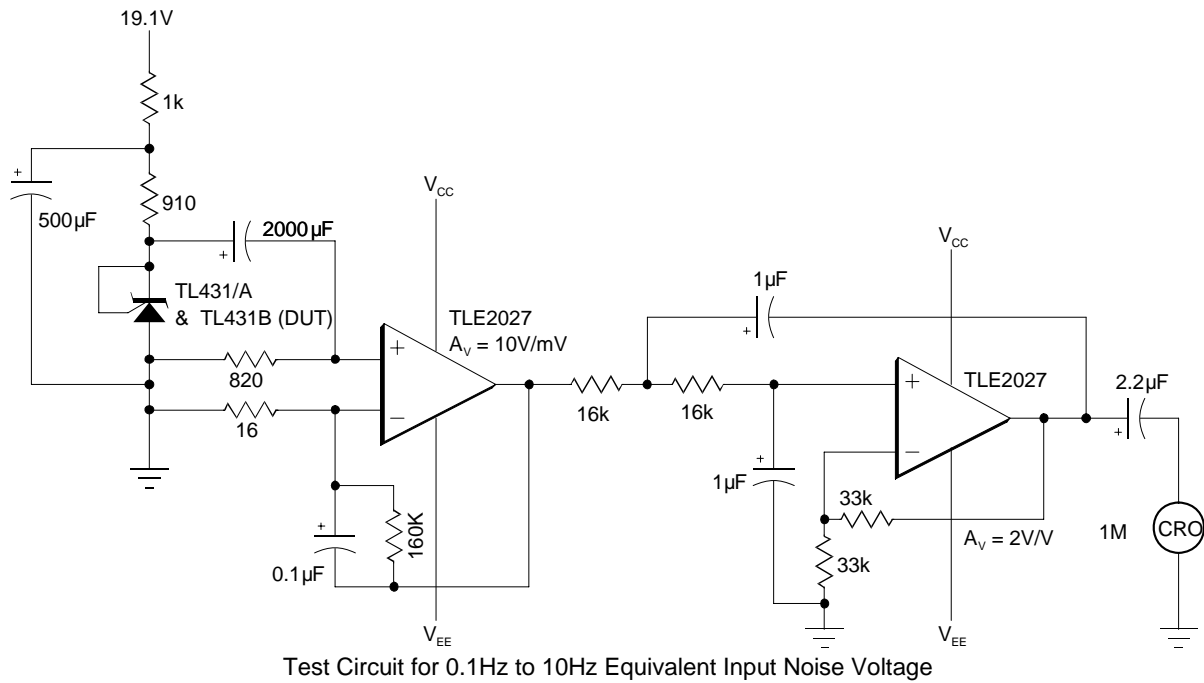
**Figure 3 – Cathode Current vs. Cathode Voltage**

**Figure 4 – Cathode Current vs. Cathode Voltage**

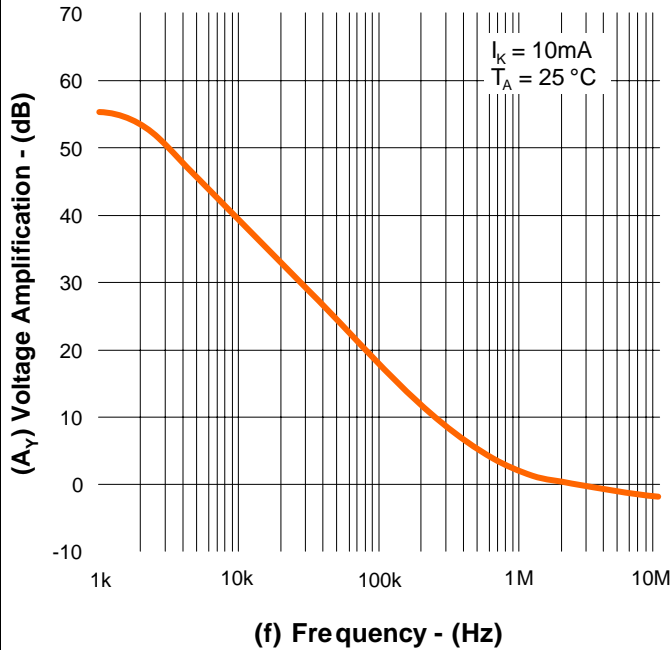
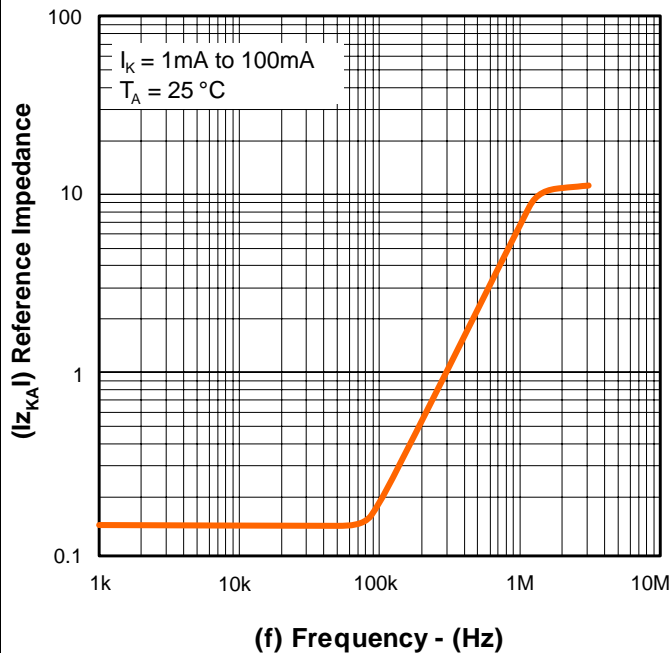
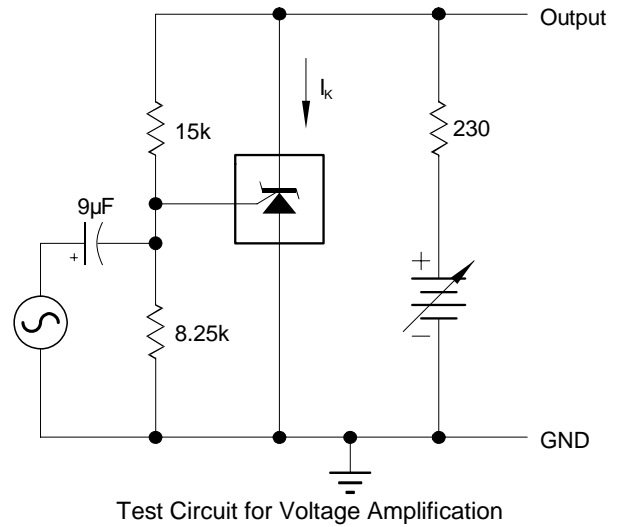
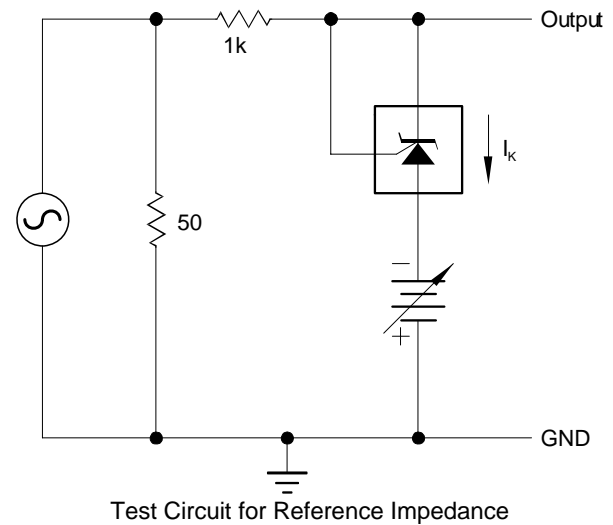
**CHARACTERISTIC CURVES**

**Figure 5 – Off-State Cathode Current vs Free-Air Temperature**

**Figure 6 – Ratio of Delta Reference Voltage to Delta Cathode Voltage vs. Free-Air Temperature**

**Figure 7 – Equivalent Input Noise Voltage vs. Frequency**

**PARAMETER MEASUREMENT INFORMATION**

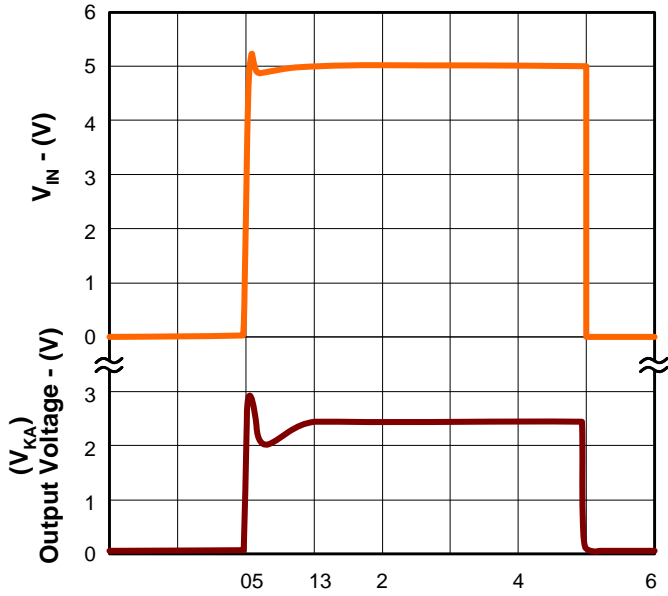
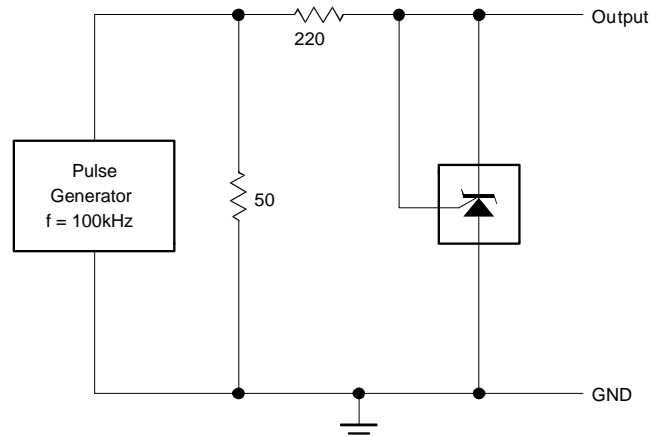
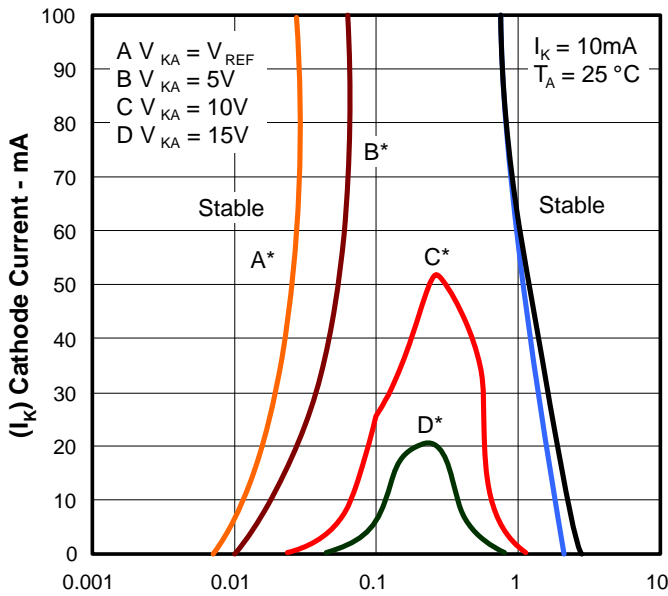
**Figure 8 – Test Circuit for  $V_{KA} = V_{REF}$** 

**Figure 9 – Test Circuit for  $V_{KA} > V_{REF}$** 

**Figure 10 – Test Circuit for  $I_{OFF}$**

**TYPICAL CHARACTERISTICS**

**Figure 11 – Equivalent Input Noise Voltage over a 10 – Second Period**



**TYPICAL CHARACTERISTICS**

**Figure 12 – Reference Impedance vs. Frequency**

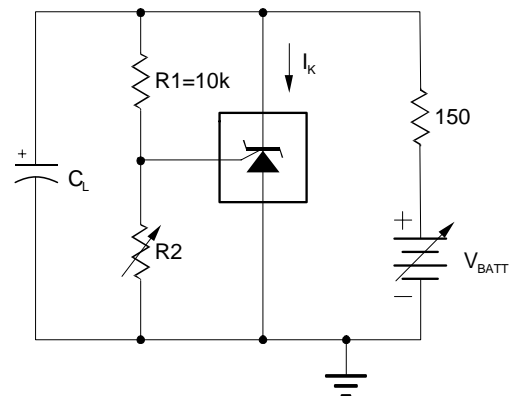
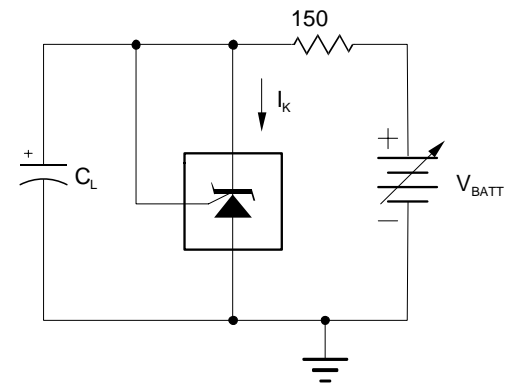
**Figure 13 – Reference Impedance vs. Frequency**

**TYPICAL CHARACTERISTICS**

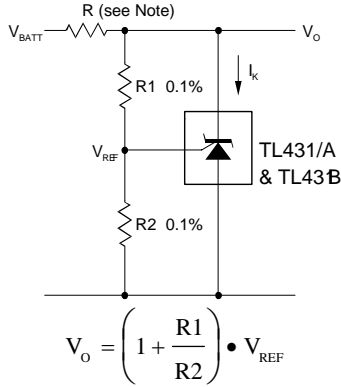
**(t) Time - ( $\mu$ s)**
**Figure 14 – Pulse Response**

**Test Circuit for Pulse Response**

**( $C_L$ ) Load Capacitance - ( $\mu$ F)**
**Figure 15 – Stability Boundary Conditions**

\*The areas under the curves represent conditions that may cause the device to oscillate. For curves B, C, and D, R2 and V+ were adjusted to establish the initial  $V_{KA}$  and  $I_K$  conditions with  $C_L = 0$ .  $V_{BATT}$  and  $C_L$  were then adjusted to determine the ranges of stability.

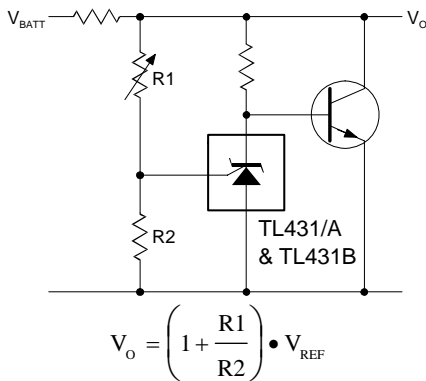
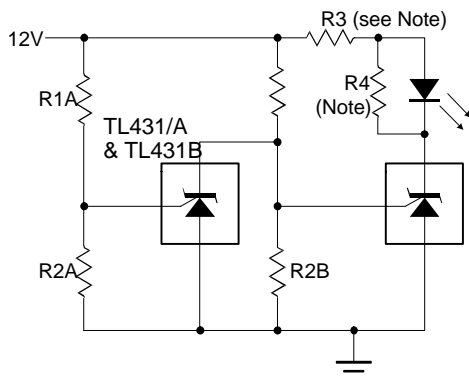
**Test Circuit for Curve A**

**Test Circuit for Curve B, C, D**

**APPLICATION INFORMATION**

**Figure 16 – Shunt Regulator**

Note: R should provide > 1mA cathode current to the TL431/A & TL431 at minimum  $V_{BATT}$

**Figure 18 – High Current Shunt Regulator**

$$\text{Low Limit} = \left(1 + \frac{R1B}{R2B}\right) \cdot V_{REF}$$

$$\text{High Limit} = \left(1 + \frac{R1A}{R2A}\right) \cdot V_{REF}$$

LED on when Low Limit <  $V_{BATT}$  < High Limit

**Figure 20 – Voltage Monitor**

Note: R3 and R4 are selected to provide the desired LED intensity and > 1mA cathode current to the TL431/A & TL431B at the available  $V+$

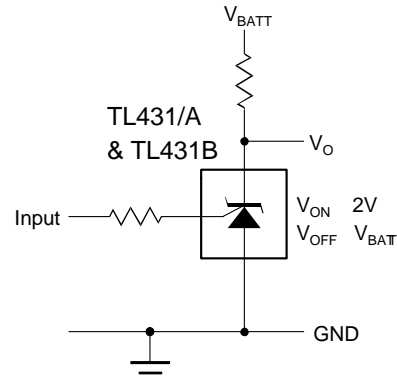
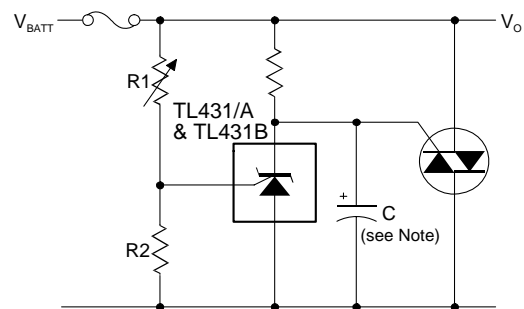
**Figure 17 – Single-Supply Comparator with Temperature-Compensated Threshold**

**Figure 19 – Crowbar Circuit**

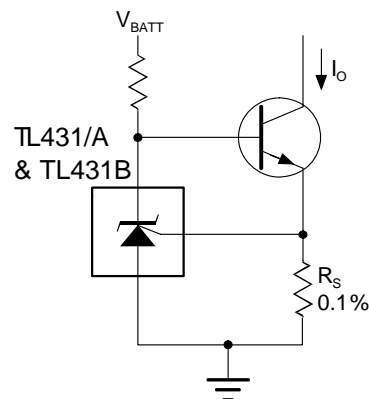
Note: Refer to the stability boundary conditions in Figure 15 to determine allowable values for C.

**Figure 21 – Precision Contact – Current Sink**